

The logo for BBK, consisting of the letters 'BBK' in a bold, dark blue, sans-serif font. The letters are slightly shadowed, giving them a three-dimensional appearance as if they are floating above a light grey rectangular base.

# **BBK**

***POWER SYSTEMS***

## **Industrial Power Systems & Marine Electrification Solutions**

UPS Systems | Frequency Conversion Systems | Shore Power  
Systems | DC Power Systems | Energy Storage Solutions

# Overview of BBK



Operating in the fields of power electronics, energy conversion, and marine electrification, BBK Power Systems delivers engineering and system integration solutions for industrial facilities, energy infrastructures, and marine applications.

## INDUSTRIAL POWER SYSTEMS

- Industrial UPS Systems
- DC Power Systems
- Rectifier Systems
- Critical Power Infrastructure

## FREQUENCY CONVERSION SYSTEMS

- Static Frequency Converters
- Power Conversion Systems
- 50/60 Hz Power Solutions
- Custom Power Conversion Systems

## MARINE ELECTRIFICATION

- Shore Power Systems
- Shore Power Pedestals
- Cold Ironing Solutions
- IEC/IEEE 80005 Solutions

## ENERGY STORAGE SOLUTIONS

- Energy Storage Systems (ESS)
- Off-Grid Applications
- Hybrid Energy Systems

## MOBILE POWER SOLUTIONS

- Trailer-Mounted Systems
- Containerized Solutions
- Temporary Power Infrastructure

***Tailored Power Electronics Solutions***

# ABOUT US



BBK Power Systems is an engineering company specializing in power electronics, energy conversion, and marine electrification solutions. By combining the advanced technologies of its global partners with local engineering expertise, the company delivers application-specific power systems tailored to the requirements of industrial and marine environments.

As a project partner, BBK Power Systems goes beyond conventional product supply by contributing to the adaptation and configuration of advanced power conversion technologies to meet project-specific requirements. Site conditions, environmental factors, power quality expectations, and operational requirements are evaluated through a comprehensive engineering approach to ensure optimum system performance and long-term reliability.

Mechanical and electrical protection, voltage and frequency conversion, power distribution, communication, and control infrastructures are integrated into complete solution architectures designed to meet demanding operating conditions and industry standards. From project engineering, production line inspections, and factory acceptance tests to commissioning, site testing, technical documentation, and lifecycle support, every stage is carried out in accordance with internationally recognized standards and established engineering practices.

With the strength of global technology partnerships and a strong commitment to engineering excellence, BBK Power Systems serves as a trusted engineering partner for industrial facilities, energy infrastructures, shipyards, ports, and marine applications, delivering reliable, sustainable, and high-performance power solutions.



# INDUSTRIAL POWER SYSTEMS



The continuous supply of reliable and high-quality power to critical loads is fundamental to the uninterrupted operation of industrial facilities. Designed to accommodate different voltage levels and power requirements within a unified architecture, our solutions are developed with a strong focus on safety, environmental conditions, and compliance with international standards. Tailored to operational needs, these systems are delivered as complete turnkey solutions, encompassing engineering, system integration, and commissioning services.

## Solution Portfolio

- Industrial UPS Systems
- Outdoor UPS Systems
- Distributed Modular Architecture Systems
- AC & DC Power Systems
- AC & DC UPS Systems
- DC Power Systems
- Rectifier Systems
- Static Voltage Regulators
- Isolation Transformers

## Key Applications

- Shipyards and Ports
- Marine and Offshore Vessels
- Industrial Facilities
- Energy Infrastructure
- Railway Systems
- Data Centers
- Tunnel and Infrastructure Projects

## Key Features

- Wide protection class range from IP21 to IP55
- Integrated battery configuration
- Integrated AC distribution MCBs
- Replaceable cassette-type dust filters
- Built-in dry contact interfaces and remote control functions (Start, Stop, Bypass and Online Mode)
- Optional integrated isolation transformer
- Optional DC outputs and DC distribution MCBs
- Optional dust filter clogging detection
- Optional output insulation monitoring
- Optional battery monitoring system



**IP55 OutDoor UPS**

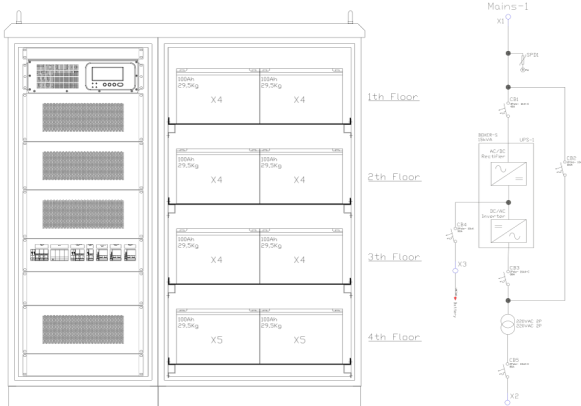

## Grid Configurations

- Input: TT / TN / IT (1P+N+PE, 3P+N+PE or 3P+PE)
- Output: TT / TN / IT (1P+N+PE, 3P+N+PE or 3P+PE)
- Input and output topologies can be configured according to project-specific requirements and system architectures.

# INDUSTRIAL POWER SYSTEMS



## Key Features

- IP65 protection class with integrated HVAC system
- External battery cabinet with IP65 protection class and integrated HVAC system
- Integrated AC distribution MCBs
- Built-in SNMP interface, dry contact outputs and remote control functions (Start, Stop, Bypass and Online Mode)
- Optional integrated isolation transformer
- Optional DC outputs and DC distribution MCBs
- Optional output insulation monitoring
- Optional battery monitoring system
- Double-wall enclosure with rock wool thermal insulation

## Grid Configurations

- Input: TT / TN / IT (1P+N+PE, 3P+N+PE or 3P+PE)
- Output: TT / TN / IT (1P+N+PE, 3P+N+PE or 3P+PE)
- Input and output topologies can be configured according to project-specific requirements and system architectures.

## Key Applications

- Shipyards and Ports
- Marine and Offshore Vessels
- Industrial Facilities
- Energy Infrastructure
- Railway Systems
- Data Centers
- Tunnel and Infrastructure Projects



**IP65 Outdoor UPS**



**IP65 Outdoor batt. cab.**

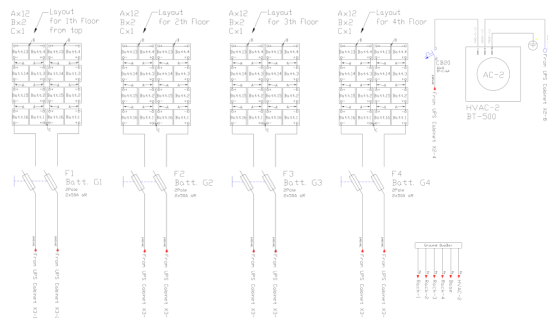
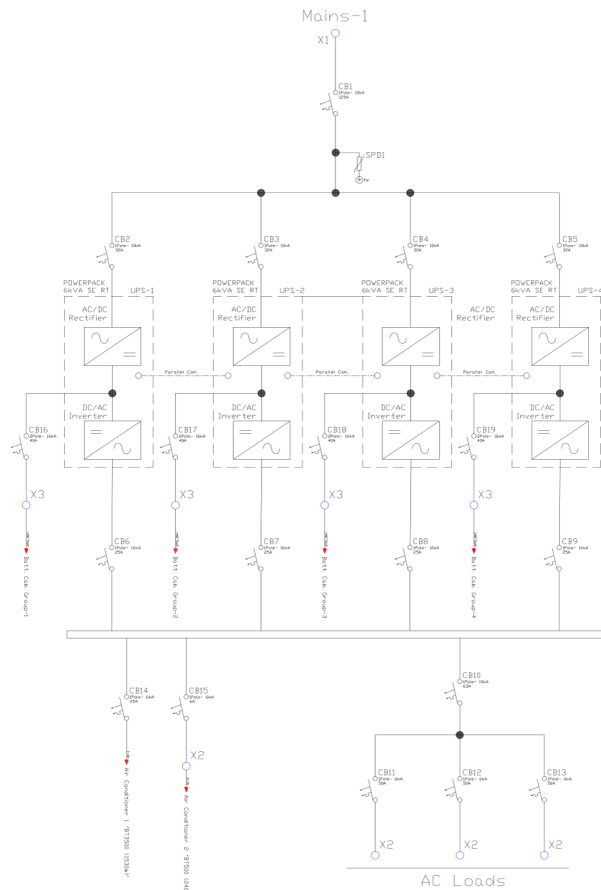

# FREQUENCY CONVERSION SYSTEMS

Reliable and high-quality power conversion between different voltage and frequency systems is essential for marine, industrial, and critical infrastructure applications. Depending on project requirements, BBK Power Systems offers both distributed modular architecture power converters and conventional solutions based on proven thyristor technology. Engineered for high efficiency, low harmonic distortion, flexible power scalability, simplified maintenance, and environmental suitability, these systems are designed in accordance with international standards and operational requirements. Delivered as complete turnkey solutions, they are supported by engineering, system integration, and commissioning services.

## Key Features

- Distributed modular architecture with automatic fault isolation
- Continuous operation through physical isolation of faulty modules
- High availability and operational reliability
- MW-level scalability with N+1 modular redundancy or N+N active parallel operation
- 100 kVA / 90 kW module rating @ 400 VAC
- Wide operating voltage range from 110 VAC to 480 VAC
- Transformer-supported 690 VAC applications
- Bidirectional 50/60 Hz and 60/50 Hz frequency conversion
- Designed for Cold Ironing (LVSC) applications
- Seamless Ship-to-Shore and Shore-to-Ship transfer capability
- Generator-compatible operation with droop control
- Microgrid and islanded operation capability
- Active load-sharing functionality
- Four-quadrant operation capability
- Conventional motor drive mode
- Standard RS-485 Modbus RTU and TCP/IP communication interfaces
- Remote start and stop functions

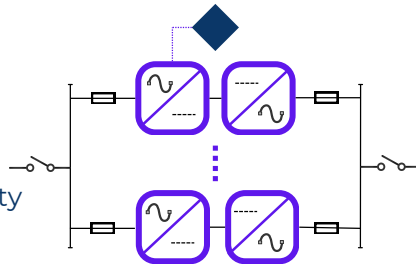

**Distributed Modular Power Converter**

## Operating Mode

1. **Former Mode (Droop Control)**
  - Designed for Cold Ironing applications
  - Suitable for Microgrid operation
  - Communication-free power scaling capability
2. **Follower Mode (Droop Control)**
  - Active load sharing functionality
3. **Motor Drive Mode**
  - Conventional variable-speed motor drive operation

## Key Applications

- Cold Ironing Systems for Ports (LVSC)
- Dry Dock Pumping Systems
- Shipyard Shore Power Supply Systems
- Industrial Facilities
- Power Conversion Systems

## Other Types Frequency Converter



**THYRISTOR-BASED  
FREQUENCY CONVERTER**



**IGBT-BASED  
FREQUENCY CONVERTER**

# MARINE ELECTRIFICATION

Rising demands for energy efficiency, emission reduction, and operational continuity are increasing the importance of shore power and power conversion technologies across the maritime industry. BBK Power Systems delivers reliable and sustainable solutions for ports and marine applications. Designed in accordance with IEC/IEEE 80005 standards, the systems are tailored to meet specific voltage, frequency, and operational requirements. From engineering and project design to system integration and commissioning, every stage is managed to provide reliable, efficient, and application-oriented solutions.

## Solution Portfolio

- Shore Power Systems
- Shore Power Pedestals
- Cold Ironing Solutions
- Static Frequency Converter Systems
- Static Power Converter Systems
- IEC/IEEE 80005 Compliant Solutions
- Port Electrification Solutions

## Key Applications

- Shipyards
- Ports
- Passenger and Cargo Vessels
- Offshore Platforms
- Naval Platforms
- Shore Power Infrastructure

## Key Features (SFC)

1.6 MVA, 400–440–480 VAC 50 Hz 3W+PE / 480 VAC 60 Hz 3W system with integrated input and output switchboards, remote operator panel, public address system, fire detection and FM-200 extinguishing system, certified cable transit system, and DNV-certified offshore design.



## Key Features – Cold Ironing / Shore Power (LVSC)

An IEC/IEEE 80005-3 and IEC/IEEE 80005-2 compliant Low Voltage Shore Connection (LVSC), Cold Ironing, Onshore Power Supply (OPS) and Shore Power System solution designed for modern port electrification applications. The system consists of Medium Voltage Switchgear (MV Switchgear), MV/LV Distribution Transformer, 1.6 MVA Modular Power Converter, Energy Management System (EMS), Fiber Optic Communication Network, 2 × 800 kVA Isolation Transformers, and four LVSC Shore Connection Panels, each equipped with 3 × 450 A shore outlets. Its modular distributed architecture supports ship power supply at 400 / 440 / 480 / 690 VAC, 50/60 Hz. The integrated HVAC system, FM-200 fire suppression system, and IACS-approved design provide a reliable and future-ready Ship Shore Power, Alternative Maritime Power (AMP), Shore-to-Ship Power, and Port Electrification solution for commercial ports, container terminals, shipyards, naval facilities, and marinas.



# DC POWER SYSTEMS

The reliable supply of protection, control, communication, and auxiliary service loads is of critical importance across a wide range of industrial applications, particularly in power generation, transmission, and distribution infrastructures. Developed to ensure high system availability and extended service life, industrial DC power systems can be configured to accommodate various voltage levels and redundancy requirements, with safety, continuity, and ease of maintenance prioritized in accordance with international standards.

Engineered for demanding operating environments, these platforms provide exceptional reliability in dusty, vibration-prone, and harsh conditions through their railway-certified designs, natural cooling concepts, and fanless architectures with no moving parts. This approach not only minimizes maintenance requirements but also delivers sustainable operational benefits throughout the system lifecycle.

A five-year warranty reflects confidence in the quality and reliability of the product platform, while an MTBF exceeding 1.8 million hours provides an outstanding level of dependability for critical infrastructure applications where maximum availability is essential.

## Solution Portfolio

- Uninterruptible DC Power Systems for Critical Loads
- Protection, Control and Communication Infrastructure Solutions
- Redundant and Modular DC Power Systems
- Auxiliary Service Power Systems for Generation and Distribution Facilities
- Naturally Cooled, Low-Maintenance Platforms
- Railway-Certified High-Reliability Platforms
- Application-Specific Battery Technologies and Autonomy Configurations
- Modernization and Capacity Upgrades for Existing Installations
- Industrial DC Power Solutions for Harsh Environments

## Key Features

- Modular Architecture
- Natural Convection Cooling Design
- Fanless Design with No Moving Parts
- Certifications for Railway Applications
- Suitable for Dusty and High-Vibration Environments
- Low Maintenance Requirements
- High System Availability
- Hot-Swappable Rectifier Modules
- 24 / 48 / 110 / 125 / 220 VDC Configurations
- 5-Year Manufacturer's Warranty
- MTBF Exceeding 1.8 Million Hours

## Key Applications

- Transformer Substations
- Power Generation and Distribution Facilities
- Protection and Control Systems
- SCADA and Auxiliary Service Infrastructures
- Railway Signaling Systems
- Metro and Rail Transit Applications
- Telecommunication Infrastructures
- Oil, Gas, and Petrochemical Facilities
- Marine and Port Electrification Systems
- Process Industries
- Data Centers and Critical Power Infrastructures
- Water Treatment and Utility Facilities
- Auxiliary Service Systems for Renewable Energy Applications



## HIGHLIGHTS

- 5-Year Manufacturer's Warranty
- MTBF > 1.8 Million Hours
- Natural Convection Cooling Technology
- N+1 Modular Redundancy Architecture

# ENERGY STORAGE SOLUTIONS



Energy storage encompasses far more than large-scale lithium-ion battery systems. It plays a vital role in ensuring power continuity, maintaining power quality, managing transitions between energy sources, and improving overall system efficiency. Depending on application requirements, energy storage solutions can be implemented across a wide range of capacities and technologies.

In facilities with multiple power sources, energy storage systems provide the response time required for controlled source transitions, support load sharing between sources, and supply short-term power demands. Likewise, in applications characterized by high peak power requirements and relatively low average energy consumption, energy storage enables more efficient and economical system designs by supplying additional peak power without oversizing the entire power infrastructure.

Energy storage solutions cover a broad spectrum of applications, ranging from UPS and battery-backed rectifier systems to micro-scale power converters and MW-class containerized energy storage installations. As such, energy storage should be regarded not as a single product or technology, but as a diverse family of solutions tailored to specific operational requirements.

Similarly, energy storage technologies are not limited to lithium-ion batteries. Depending on environmental conditions, expected service life, maintenance requirements, and investment considerations, lead-based batteries (Carbon Lead, OPzV, OPzS, etc.), Ni-Cd batteries, and other storage technologies may provide more suitable and advantageous alternatives.

BBK Power Systems adopts a technology-neutral approach to energy storage. Rather than focusing on a single chemistry or platform, the company evaluates application requirements and develops the most appropriate solution by selecting from a wide range of energy storage technologies and system architectures.

## Solution Portfolio

- Power Continuity and Backup Energy Solutions
- Source Transfer and Load Sharing Systems
- Peak Shaving and Generator Support Solutions
- Generator Optimization and Fuel Efficiency Solutions
- Off-Grid and Hybrid Power Systems
- Mobile and Containerized Energy Storage Systems
- Application-Specific Battery Technologies

## Key Applications

- Industrial Facilities
- Power Generation and Distribution Infrastructure
- Marine and Port Applications
- Temporary Power Installations and Construction Sites
- Off-Grid Communities and Isolated Locations
- Data Centers and Critical Power Applications
- Renewable Energy and Microgrid Applications
- Mobile Power Systems
- Remote and Harsh Environment Applications

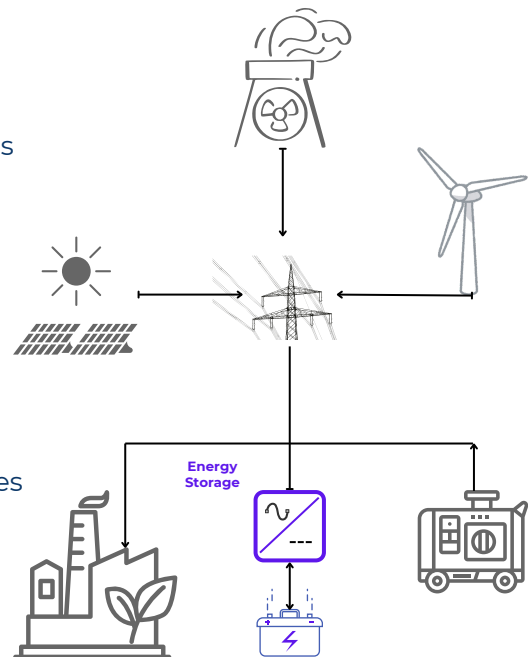

# MOBILE POWER SOLUTIONS

BBK Power Systems delivers flexible and scalable mobile power solutions tailored to a wide range of site conditions and project requirements. Configured within trailer-mounted platforms, containerized systems, and outdoor enclosures, these solutions are engineered for rapid deployment, ease of transportation, and reliable long-term operation.

## Solution Portfolio

- Mobile Power Systems
- Containerized Energy Solutions
- Outdoor Enclosure Systems
- Off-Grid Power Systems
- Hybrid Power Systems
- Modular Energy Infrastructure

## Mobile Frequency Converter Systems

Trailer-mounted mobile frequency converter systems are designed to provide mobility, flexibility, and rapid deployment for temporary power applications, port operations, maintenance activities, and specialized power conversion projects.

Depending on application requirements, the system can be equipped with an integrated HVAC unit, external connection box, surge protection devices (SPD), and MCCB protection on the input side, while the output side may incorporate MCCB, RCD, and energy metering devices. An integrated power analyzer enables continuous monitoring of system parameters and energy consumption. Optional configurations with an integrated isolation transformer are also available.

## Containerized frequency converter solutions ;

offer compact small, medium and large scale plug-and-play systems for applications requiring temporary power conversion or where indoor space utilization must be minimized. Engineered for harsh environmental conditions, these compact and integrated solutions incorporate built-in HVAC and FDSS systems and comply with applicable standards while allowing additional features and functionalities to be tailored to specific project requirements.



## Key Applications

- Emergency Power Systems
- Port and Marine Applications
- Defense and Security Projects
- Mobile Command and Control Centers
- Remote Communities and Off-Grid Locations
- Temporary Power Installations



## Key Features

- Available in Trailer-Mounted or Containerized Configurations
- Designed for Easy Transportation, Rapid Installation, and Fast Commissioning
- Integrated HVAC Climate Control System
- External Connection Box (Junction Box)
- Input Protection with SPD and MCCB
- Output Protection with MCCB, RCD, and Energy Metering Devices
- Integrated Power Analyzer for System Monitoring
- Optional Integrated Isolation Transformer



# LVSC SHORE POWER PANELS

Low Voltage Shore Connection (LVSC) systems are designed to reduce onboard auxiliary generator operation and minimize emissions during port stays, providing safe, seamless, and high-quality power transfer between vessels and the shore grid.

Designed in accordance with IEC/IEEE 80005-3 and IEC/IEEE 80005-2 standards, the systems are configured to accommodate various voltage, frequency, and operational requirements and are supported by integrated protection, metering, communication, and control infrastructures.

Configurable according to vessel type, power level, and port operating requirements, the solutions offer a flexible architecture capable of supporting multiple connection methods, load-sharing strategies, and multi-vessel supply scenarios. In addition to vessels equipped with standard shore power interfaces, dedicated solutions can also be provided for vessels without native IEC/IEEE 80005-2 communication capability, while maintaining safety, operational continuity, and system reliability as primary design objectives.

## Solution Portfolio

- Low Voltage Shore Connection (LVSC) Systems
- Shore Power and Cold Ironing Solutions
- Vessel-Specific Power Distribution Architectures
- Multi-Vessel Supply and Load Sharing Solutions
- Protection, Metering, and Energy Monitoring Infrastructures
- Application-Specific Power Distribution and Protection Systems

## Key Features

- IEC/IEEE 80005-3 compliant design
- Configurable for 400 V, 440 V, and 690 V applications
- Support for 50 Hz and 60 Hz operation
- 250 A and 400 A output configurations
- Pilot circuit and safety interlock connection system
- High short-circuit withstand capability with selective protection architecture
- Integrated MCCB, RCD, and energy metering functions
- Power analyzer and remote monitoring capabilities
- Stainless steel and marine-grade enclosure options
- Flexible architecture supporting various voltage, frequency, and connection requirements
- Long service life under demanding marine environmental conditions



## Key Applications

- Commercial and Naval Ports
- Passenger Terminals
- Shipyards
- Fishing Harbors and Small Craft Ports
- Marina Infrastructure
- Offshore Support Facilities
- Emission Reduction and Decarbonization Projects

## Key Advantages

- 1. Supporting Sustainable Port Operations**
  - Helps reduce emissions by minimizing onboard auxiliary generator operation during port stays.
- 2. Flexible Connection Architecture**
  - Dedicated solutions can be implemented for both standard shore-connected vessels and vessels without native IEC/IEEE 80005-2 communication capability, ensuring safe and reliable operation.
- 3. Support for Multiple Voltage and Frequency Levels**
  - Configurable for 400 V, 440 V, and 690 V systems with 50 Hz and 60 Hz operating capability.
- 4. Application-Oriented Design**
  - Protection, metering, connection, and power distribution architectures can be customized according to vessel type, port infrastructure, and operational requirements.



# SHORE POWER PEDESTALS

Developed for marinas, fishing harbors, piers, and waterfront facilities, Shore Power Pedestals provide safe and organized access to electrical power for vessels while integrating power distribution, metering, and protection functions within a single compact structure. Configurable for different current ratings, socket configurations, and installation requirements, the systems are designed with user safety, environmental conditions, and long-term operational reliability in mind. A wide range of options, including metering, protection, and remote monitoring functions, enables application-specific solutions for various marine and waterfront infrastructures.

## Solution Portfolio

- Power Distribution Systems for Marinas and Fishing Harbors
- Shore Power Pedestals for Piers and Waterfront Facilities
- Wall-Mounted and Free-Standing Configurations
- Energy Metering and Consumption Monitoring Solutions
- Application-Specific Socket and Protection Architectures
- Remote Monitoring and Communication Systems

## Key Features

- IEC 60309 compliant 16 A and 32 A socket outlets
- 230 VAC, 1P+N+PE output configuration
- Integrated MCB, RCD, and SPD protection options
- MID-certified energy meters and power analyzer options
- IP54-rated enclosure design
- Stainless steel and corrosion-resistant enclosure options
- Available in free-standing and wall-mounted configurations
- Remote monitoring and communication capabilities
- Flexible architecture tailored to application requirements

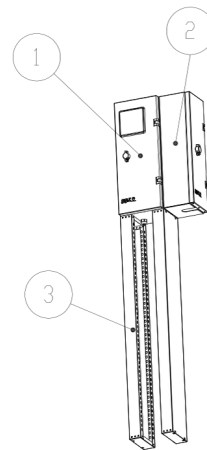
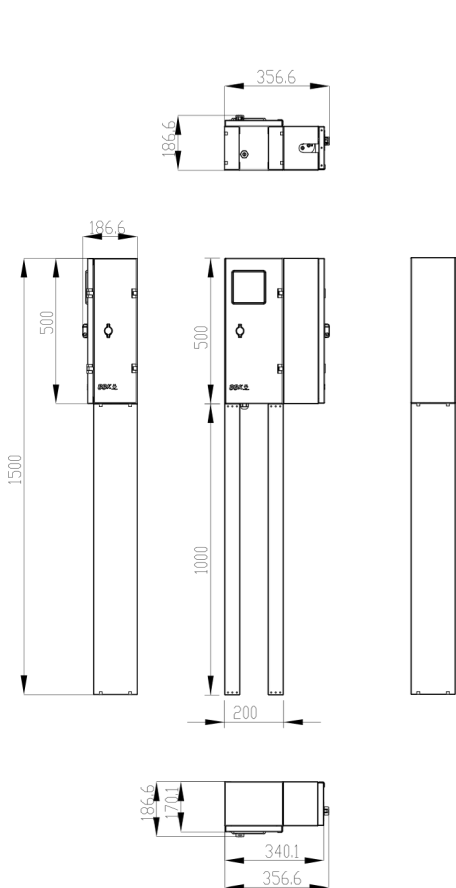

No	Descriptions
1	AC Input Panel
2	AC PLUG Outlet
3	Pedestal

## Key Applications

- Marinas
- Fishing Harbors
- Yacht and Boat Marinas
- Tour Boat and Passenger Piers
- Waterfront Facilities
- Port Service Areas
- Campgrounds and Recreational Vehicle (RV) Parks
- Aquaculture and Marine Facilities

## KEY ADVANTAGES

- Safe and Controlled Power Distribution
- Individual Energy Consumption Metering
- Ease of Operation and Maintenance
- Long Service Life in Marine Environments
- Modular and Expandable Architecture
- Flexible Design Tailored to User Requirements

# POWER ELECTRONICS AND SYSTEM INTEGRATION SOLUTIONS

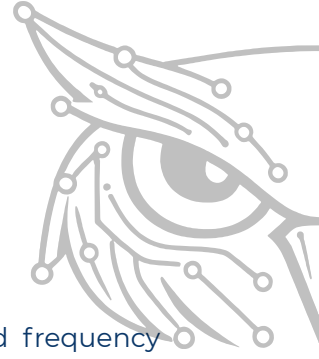

Covering a broad spectrum of applications, from industrial power systems and frequency conversion technologies to marine electrification and energy storage solutions, BBK Power Systems delivers application-specific solutions with safety, operational continuity, and operational requirements at the core of every project.

## OUR EXPERTISE

### Industrial Power Systems

Industrial UPS Systems • DC Power Systems • Rectifier Systems • Critical Power Infrastructure

### Frequency Conversion Systems

Static Frequency Converters • 50/60 Hz Power Conversion Systems • Shore Power Frequency Converters • Custom Power Conversion Systems

### Marine Electrification

Shore Power Systems • Cold Ironing Solutions • LVSC Shore Power Panels • Shore Power Pedestals

### DC Power System

Industrial Rectifier Systems • Battery Charging Systems • Backup Power Systems • Railway Applications

### Energy Storage Solutions

Hybrid Power Systems • Microgrid Applications • Mobile Energy Systems • Generator Support Applications

### Mobile Power Solutions

Trailer-Mounted Power Systems • Containerized Power Systems • Temporary Power Infrastructure • Mobile Field Applications

#### CONTACT

BBK POWER SYSTEMS

 [www.bbkelektromekanik.com](http://www.bbkelektromekanik.com)

 [info@bbkelektromekanik.com](mailto:info@bbkelektromekanik.com)

 +90 216 504 1718

 Istanbul / Türkiye

*Technical specifications and system configurations may vary depending on application requirements.*

[www.bbkelektromekanik.com](http://www.bbkelektromekanik.com)

[info@bbkelektromekanik.com](mailto:info@bbkelektromekanik.com)

O: +90 216 504 1718